

Shallow 'V' Section Sand Slurry Channels

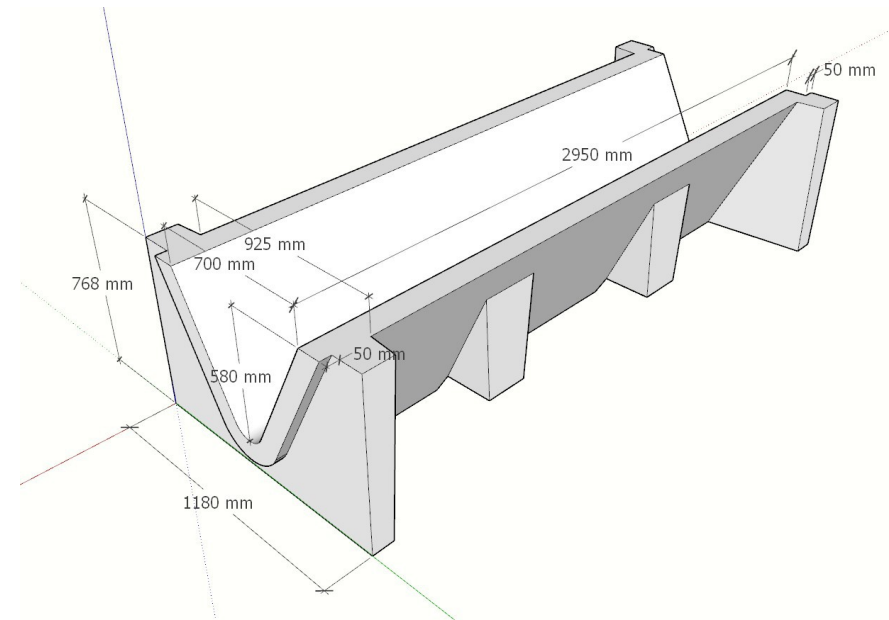

- 1815kg - 2950mm x 768mm x 1180mm (approx. 9'8" x 3'11" x 2')
- Integrated fork slots for easy unloading on delivery
- Four M16 lifting eyes cast in to the inner surfaces for threaded lifting loops
- V-section shape to increase flow rate at bottom of channel
- 50mm interlocking lip and rebate (overall length is 3000mm inc. lip)

Endford Works, Shebbear, Devon, EX21 5RY
01409 281437 – 07970 520123
info@westcountryconcreteproducts.co.uk

West
Country
Concrete
Products